

# Other flap fittings



- ▶ Flap lift fitting
- ▶ HLB

## HLB



- ▶ For wooden front panels or framed wooden front panels
- ▶ Fitted with 1 or 2 gas springs
- ▶ Items with 2 gas springs: adjustable cross member permits adjustment of the width
- ▶ Two-dimensional front panel adjustment: vertical  $\pm 3$  mm, horizontal  $\pm 3$  mm
- ▶ Powder coated steel

For carcase side mm	Inside carcase width mm	Number of gas springs	Max. flap weight kg	Order no. / Colour		PU
				silver	white	
16	567	1	3.5	0 045 027	0 079 392	1 ea.
18	563	1	3.5	0 045 028	0 079 393	1 ea.
19	561	1	3.5	0 045 029	0 079 394	1 ea.
16 - 19	420 - 580	2	4	0 045 031	0 045 159	1 ea.
16 - 19	560 - 870	2	5	0 045 032	0 045 160	1 ea.

## Flap and opening dimensions

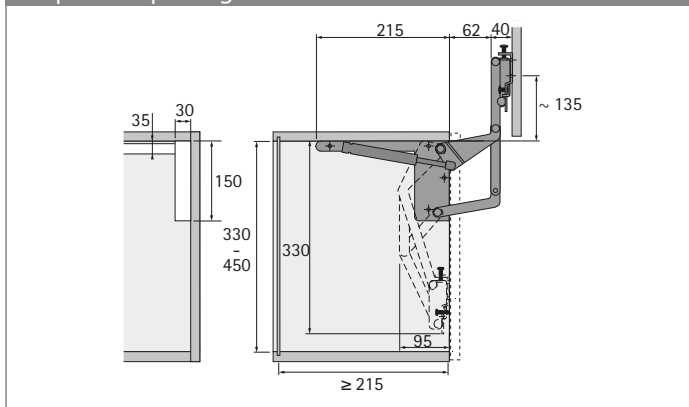

## Carcase drilling pattern

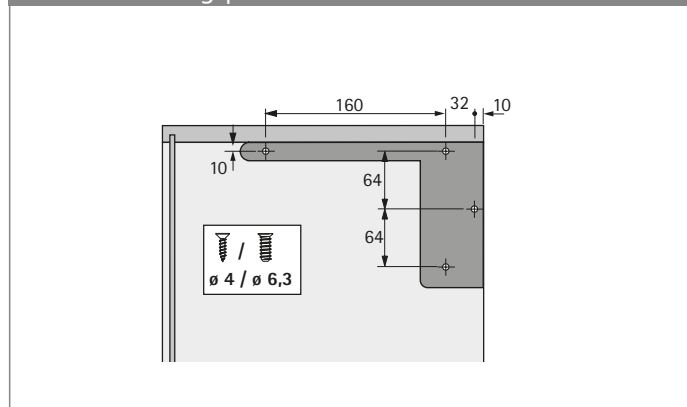

## Flap drilling pattern

