

# Drawer runners for wooden drawers

- ▶ KA 270 partial extension runner for groove installation
- ▶ Load capacity 12 kg



- ▶ Partial extension runner with pull-out stop and roll-out prevention
- ▶ Runner and ball cage form a complete, non-separable unit
- ▶ Precision control for moving smoothly and freely and high lateral stability
- ▶ For drawers with grooved, rebated or loosely fitted drawer bottom panel
- ▶ Load capacity to EN 15338, Level 1
- ▶ Galvanised steel

## KA 270 ball bearing runner, 27 mm groove

Nominal length mm	Drawer length SL mm	Extension loss EL mm	Hole spacing b1 mm	Hole spacing C mm	Carcase rail mm	Drawer runner mm	Order no.	PU
350	230 - 350	56	160	190	214	222	0 025 155	1/10 pairs
350	350 - 550	80	288	296	342	328	0 025 156	1/10 pairs

## Planning dimensions

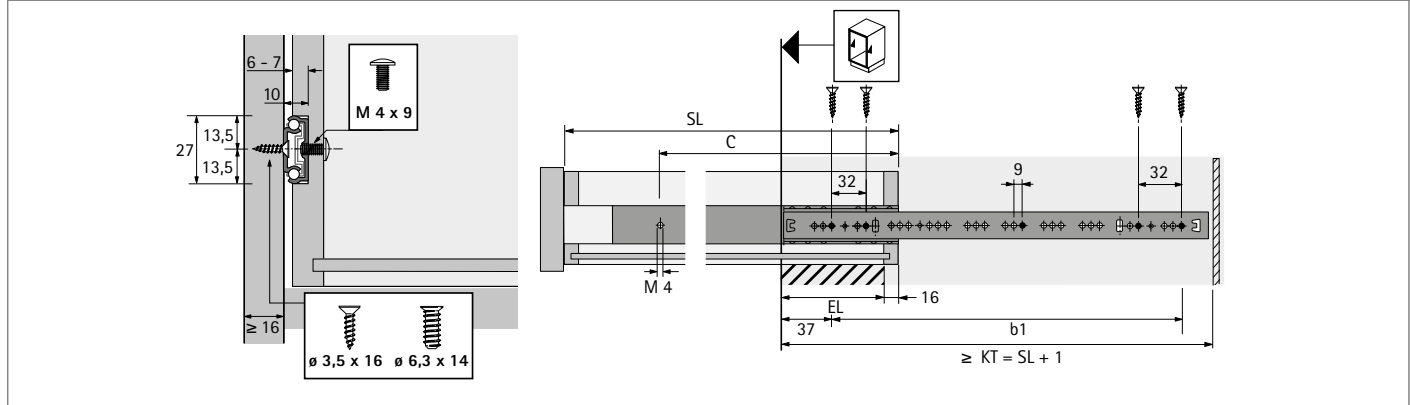

### Advice

- ▶ For technical information, see page 1610 - 1612
- ▶ For accessories, see page 1636 - 1641